



## Innovative Manual Call Point

DC-9204E



548g(cl-5) 0832-CPD-0789

### Description

Designed for the purpose of raising an alarm manually once verification of a fire or emergency condition has occurred. By pressing the non breakable glass. Meets the standard requirement of EN 54 part 11, European Standard and approved by Loss Prevention Certificate Board (LCPB).

The DC-9204E constructed of high impact red ABS with a modern pleasing appearance. The terminating back box enables first fix installation and termination leaving the fascia.. Non breakable glass that can be reset with the GST standard reset key.

### Features and Benefits

- Listed to LPCB,
- Semi-Flush mounted
- Compatible with latest EN standards
- Re-settable (non-breaking glass)
- Optional flipping plastic cover (D-92FC)
- Optional back box for surface mount
- LED indicator
- Friendly installation and test

### Technical Specifications

- Standard: EN54:11
- Approval: LPCB
- Protection rating: IP 43
- Operating voltage: 24VDC (12VDC ~ 28VDC)
- Operating current:
  - Alarm Current:  $\leq 30\text{mA}$
  - (equivalent resistance is 470  $\Omega$  /1W)
- Operating temperature:  $-10^{\circ}\text{C}$  to  $+55^{\circ}\text{C}$
- Relative humidity: 95%
- Application: Indoor use
- Visual Indicator: LED, Red ( lit steady when alarm)
- Front Cover: Plastic glass (optional)
- Material and colour: ABS, red
- Wiring: 1 pair polarized
- Dimensions(L×W×H):
  - 87mm×87mm×58mm (with backbox)
  - 87mm×87mm×23mm (without back box) mm

## Mounting Base

The manual call point should be installed in compliance with all local codes having a jurisdiction in your area or NFPA 72 National Fire Alarm Code, NFPA 70 National Electrical Code, BS 5389 and EN54. Surface mount and it is installed onto a standard one gang electrical box with a mounting hole that has 52mm~68mm spacing.

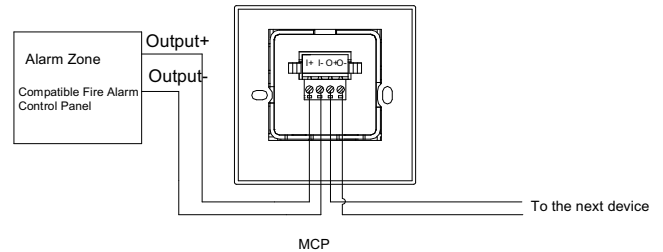
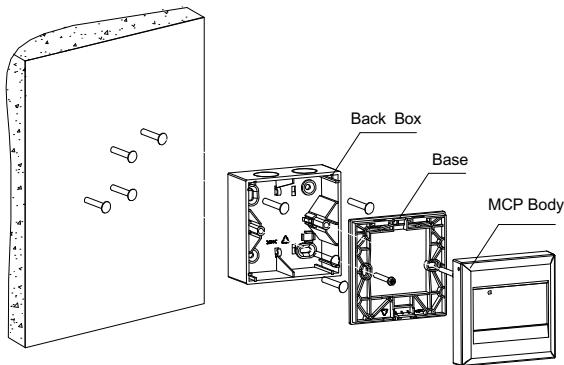

## Wiring and Connection

Terminals on the MCP base are shown:

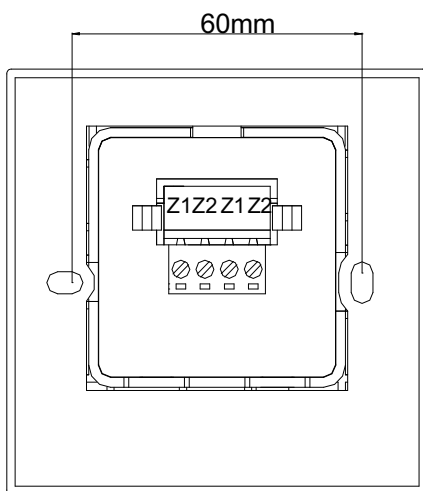

I+, I-: Input signal, connecting with compatible control panel or the previous MCP.

O+, O-: Output signal, connecting with the next MCP.

## Ordering Information



**Part Number:** DC-9204E  
**Description:** Innovative Manual Call Point  
**Weight / Kg.:** 0.16  
**Pack Qty. per Box:** 50

MANUFACTURED IN ACCORDANCE WITH

