

TX7210

Addressable Single Input/Output Module Installation and Operation Manual



Product Safety

To prevent severe injury and loss of life or property, read the instruction carefully before installing the module to ensure proper and safe operation of the system.



European Union directive

2012/19/EU (WEEE directive): Products marked with this symbol cannot be disposed of as unsorted municipal waste in the European Union. For proper recycling, return this product to your local supplier upon the purchase of equivalent new equipment, or dispose of it at designated collection points.



For more information please visit the website at www.recyclethis.info

Table of Content

1 Introduction.....	4
1.1 Overview	4
1.2 Feature and Benefits	4
1.3 Technical Specification	4
2 Installation	5
2.1 Installation Preparation.....	5
2.2 Installation and Wiring	5
3 Interface Module Configuration.....	7
3.1 Preparation	7
3.2 Write: Addressing	7
3.3 Feedback Mode	8
3.4 Input Check Mode	9
3.5 Output Check Mode	9
3.6 Read Configuration	10
4 General Maintenance	10
5 Troubleshooting Guide	11
Appendix 1	11
Limitation of Interface Module	11

1 Introduction

1.1 Overview

The TX7210 Addressable Single Input/output Module is characterized as one input or output volt free relay and control module. The unit is normally used for overriding equipment such as lift return, door holder, smoke extract fans, air handling unit, auto dialler to fire brigade, BMS and etc. The unit has built-in feedback signal feature, according to the pre-configured interface module command fire scenario, the alarm controller send out start command to the equipment required to start. After receiving the command, output module enables its relay to change state. Once the module is under control and operated a confirmation signal will be sending back to the alarm controller. In addition, the unit incorporates an intelligent processor that provides automatic monitoring for both open and short circuit of the input signal line.

The unit manufactured base on the requirement of EN 54 part 18, European Standard. The unit is aesthetically pleasing with unobtrusive design that will complement modern building designs and its plug-in type assemblies make installation and maintenance more convenient to the installer. The unit is compatible to the TX7004 Analogue Intelligent Fire Alarm Control Panel, produced by single manufacture T&A, to avoid addressable communication compatibility problem.

1.2 Feature and Benefits

- EN54-18 Compliance
- Built-in MCU processor and digital addressing
- 24Vdc/3A Output relay contact and Control module
- Input Fire or Supervisory signal configuration
- LED status indicator
- Onsite Adjustable Parameter
- Loop or external power input
- Aesthetically pleasing design
- Surface mounting with fix base for simple installation

1.3 Technical Specification

- | | |
|-----------------------------|---|
| • Listed | LPCB Pending |
| • Compliance | EN54-18:2005/AC2007 |
| • Input Voltage | Loop Power:24VDC [16V to 28V]
External PSU: 20 to 28VDC |
| • Current Consumption | Loop: Standby 0.6mA, Alarm: 1.6mA
External PSU: Standby 0.6mA, Alarm: 45mA |
| • Control output voltage | 24VDC / 3A rating |
| • Input Relay | Normally Open dry contact |
| • Input Resistance | 5.1Kohms/ ¼ W |
| • Protocol/Addressing | T&A, Value range from 1 to 254 |
| • Indicator Status | Normal: Single blink/Active: Steady/Fault: Double Blink |
| • Material / Colour | ABS / White Glossy finishing |
| • Dimension / LWH | 108 mm x 86 mm x38 mm |
| • Weight | 170g (with Base), 92g (without Base) |
| • Operating Temperature | -10°C to +50°C |
| • Ingress Protection Rating | IP30 |
| • Humidity | 0 to 95% Relative Humidity, Non condensing |

2 Installation

2.1 Installation Preparation

This interface module must be installed, commissioned and maintained by a qualified or factory trained service personnel. The installation must be installed in compliance with all local codes having a jurisdiction in your area or BS 5839 Part 1 and EN54.

T&A products has available range of interfaces, each interface module is designed for specific application, it is essential to consider the requirement of both sides of the interface to avoid malfunction and typical fault scenario. The main caution is to ensure that the voltage rating of the equipment and interface module are compatible.

2.2 Installation and Wiring

1. Mount the interface module base on standard one [1] gang electrical back box. Follow the arrow mark for the correct position. Do not over-tighten the screws otherwise the base will twist. Use two M4 standard screws.
2. Connect the wire in terminal according to the requirement as shown in Figure two [2] to five [5]. Verify the device address and other parameters then stick on the label before attaching the module. The sticker labels are available on the control panel. Align the interface module and tabs and gently pushing the device until it locks into place.

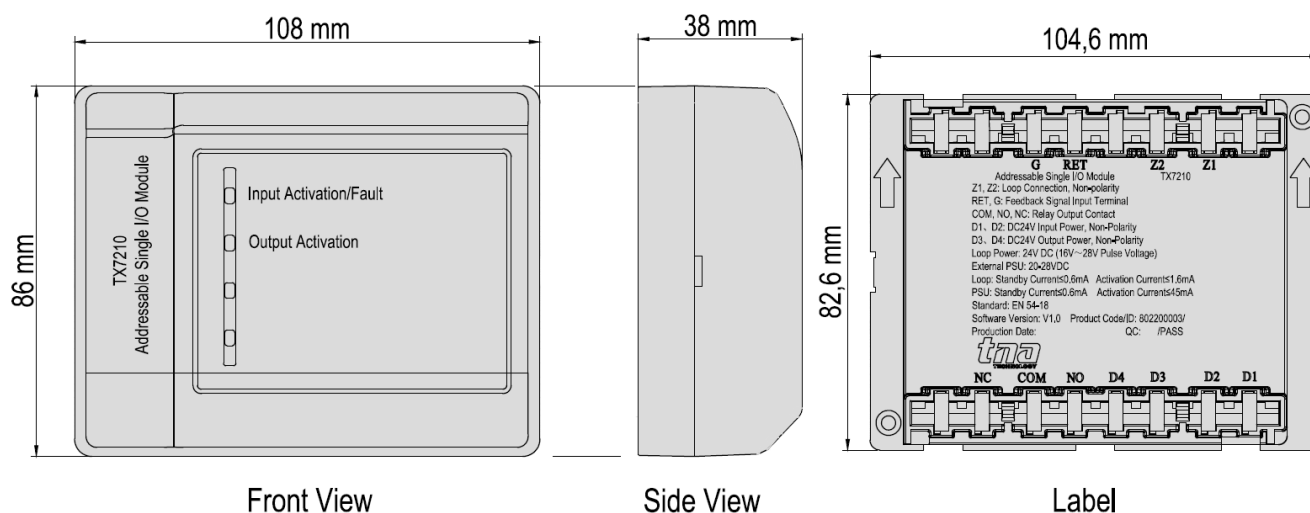

Figure 1: I/O Modules Structure

Terminal Description

- Z1 Signal In (+)
- Z1 Signal Out (+)
- Z2 Signal In (-)
- Z2 Signal Out (-)
- RET Input Cable
- G Input Cable
- D1 External Power Supply In (+)
- D2 External Power Supply In (-)
- D3 Not Use
- D4 Not Use
- COM Output Cable
- NO, NC Output Cable

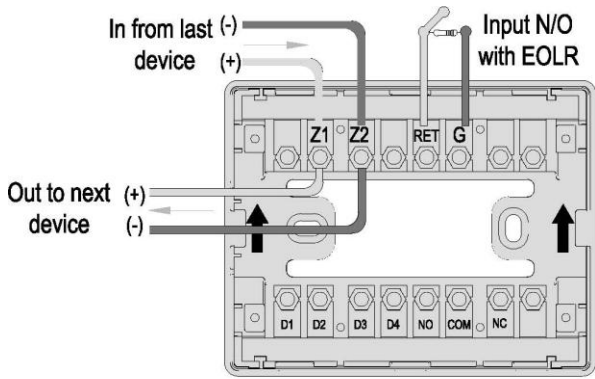

Figure 2: Input Wiring Details

Note: Change the parameter Input Check into 3Y (Loop Powered)

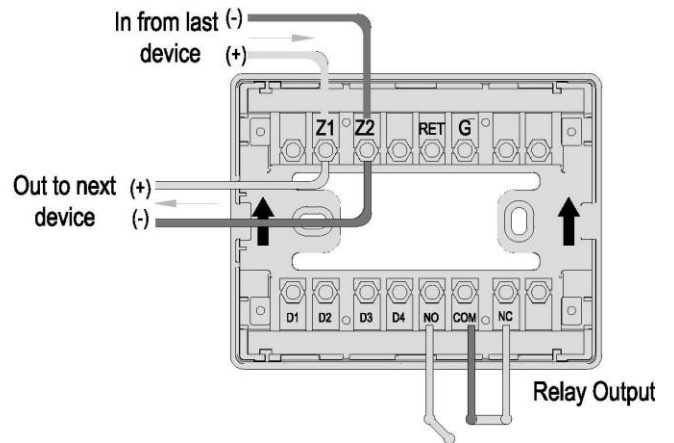

Figure 3: Relay Output Wiring Details (Loop Powered) mostly used

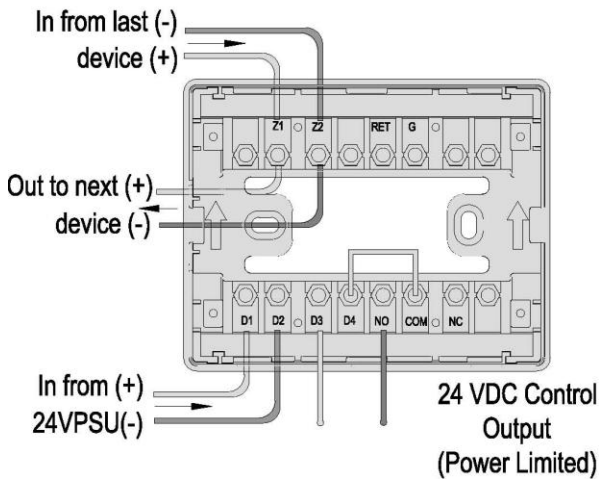

Figure 4: Control Output Wiring Details (With External Power Supply)

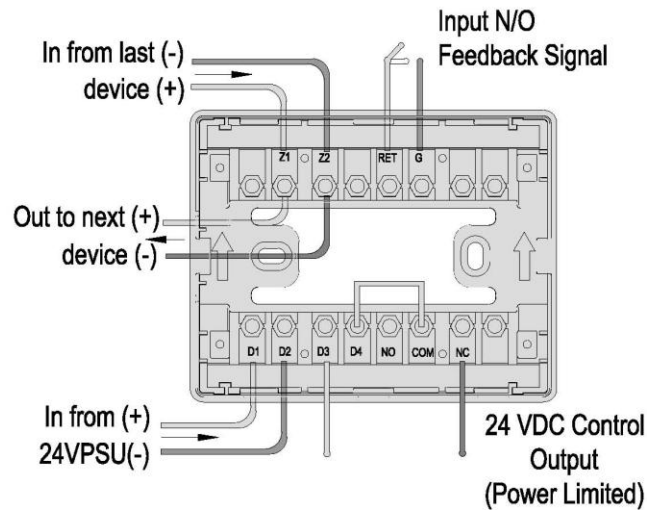

Figure 5: Control Output with Feedback Signal Wiring Details (With External Power Supply)

Signal	Monitoring	When Off (normal)	When On (active)
Input	YES (Optional)	Normally Open	Normally Close
Relay Output	Yes	Normally Open	Normally Close
		Normally Close	Normally Open
Power Limited Output	Yes	+1.5-3Vdc	+24Vdc

Input/output Parameters

Signal	Feedback	Input Check	Output Check
Input	-	3Y (Yes)- Fit with resistor - 4N (No)- No resistor is required -- Default setting	-
Relay Output	1Y (Yes)- By the SELF 2N (No)- By the EXTERNAL – (Note: in relation with the Input signal) Default setting	-	-
Power Limited Output	1Y (Yes)- By the SELF 2N (No)- By the EXTERNAL - (Note: in relation with the Input signal) Default setting	-	5Y (Yes)-Supervise 24VDC continuity - Default setting 6N (No)- No supervision

3 Interface Module Configuration

3.1 Preparation

The TX7930 handheld programmer is used to configure interface module soft address and parameter. This tools are not included, must be purchased separately. The programmer is packed with twin 1.5V AA battery and cable, ready for usage once received.

It is mandatory for the commissioning personnel to have programmer tool in order to adjust the module conferring to the site situation and environmental requirements.

Program a unique address number for each device according to the project layout before placing from the Terminal Base.

Warning: Disconnect the loop connection whilst connecting to the handheld programmer.

3.2 Write: Addressing

1. Connect the programming cable to Z1 and Z2 terminals (Figure 6). Press **“Power”** to switch on the unit.
2. Switch-on the programmer, then press button **“Write”** or number **“2”** to enter Write Address mode (Figure 7).
3. Input the desire device address value from 1 to 254, and then press **“Write”** to save the new address (Figure 8).

Note: If display **“Success”**, means the entered address is confirmed. If display **“Fail”**, means failure to program the address (Figure 9).

4. Press **“Exit”** key to go back Main Menu. Press **“Power”** key to switch-off the programmer.

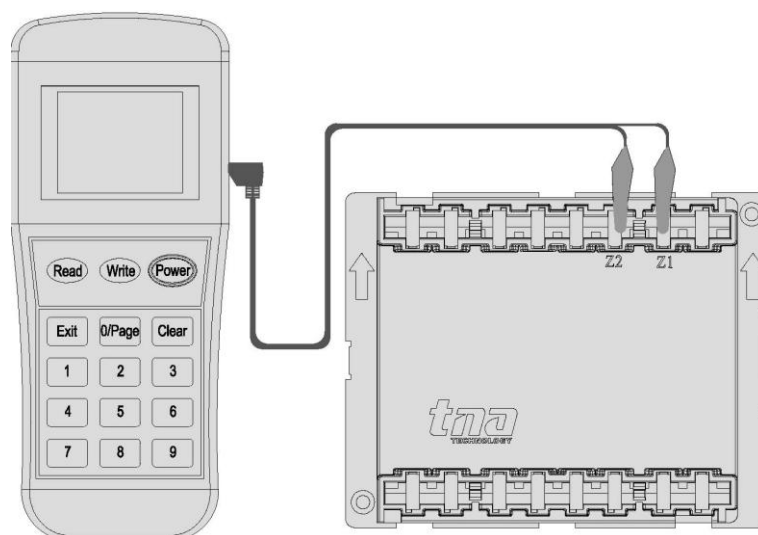

Figure 6: Programmer Connection Detail

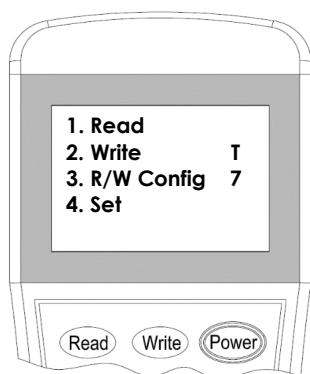

Figure 7

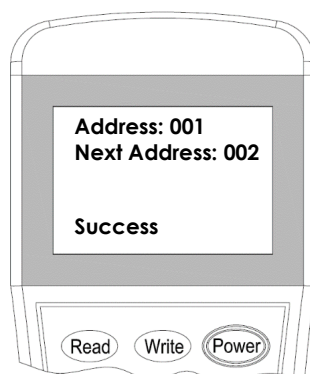

Figure 8



Figure 9

3.3 Feedback Mode

1. Feedback mode has two types, SELF and EXTERNAL. Under SELF-feedback mode, once the interface module received active command from the panel, the module automatically send feedback signal to the control panel, alongside the Feedback LED indicator goes turn-on. While the External-feedback mode will do similar action when the interface module detect feedback signal from Input terminal. Default setting is External-feedback mode.
2. Connect the programming cable to Z1 and Z2 terminals (Figure 6). Press **“Power”** to switch-on the unit.
3. Switch-on the programmer, then press button **“3”** to enter to Configuration mode (Figure 10).
4. Input the **“1”** for Self-feedback mode or **“2”** for External-feedback mode then press **“Write”** to change the setting (Figure 11).
Note: If display **“Success”**, means the entered mode is confirmed. If display **“Fail”**, means failure to program the mode.
5. Press **“Exit”** key to go back Main Menu. Press **“Power”** to switch off the programmer.

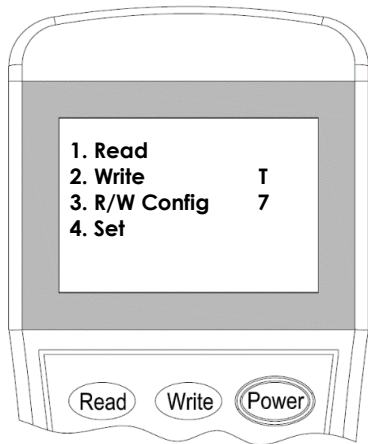

Figure 10

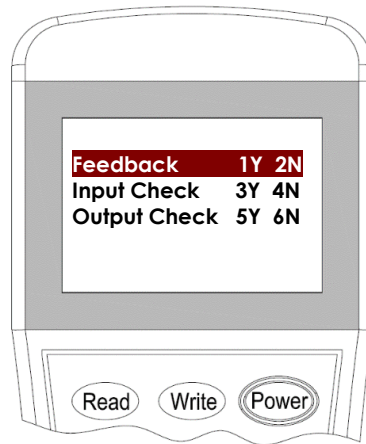

Figure 11

Parameter Description
1Y Self-Feedback Mode
2N External-Feedback Mode (Default)

3.4 Input Check Mode

1. Input Check mode is use to enable the input cable monitoring, this option is available when parameter is set to 3Y with fitted end of line resistor. The module monitor will report to the panel in the event of open or short circuit occurs in the wiring.
2. To set to check mode. Connect the programming cable to Z1 and Z2 terminals (Figure 6). Press **“Power”** to switch-on the unit.
3. Switch-on the programmer, then press button **“3”** to enter to Configuration mode (Figure 12).
4. Input the **“3”** key for Check mode then press **“Write”** to change the setting (Figure 13).

Note: If display **“Success”**, means the entered mode is confirmed. If display **“Fail”**, means failure to program the mode.

5. Press **“Exit”** key to go back Main Menu. Press **“Power”** to switch off the programmer.

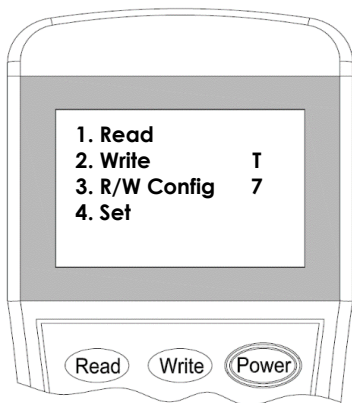

Figure 12

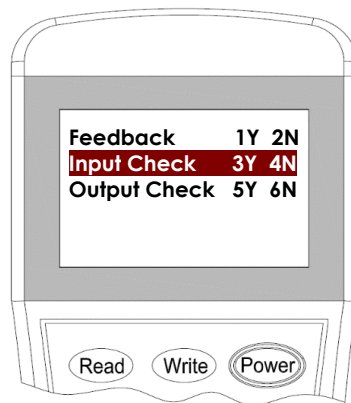

Figure 13

Parameter Description
3Y Enable Input Check Mode
4N Disable Input Check Mode (Default)

3.5 Output Check Mode

1. Output Check mode is use to enable voltage monitoring. The module will report to the panel in the event of low voltage output cause by open and short circuit occur in the wiring.
2. Connect the programming cable to Z1 and Z2 terminals (Figure 6). Press **“Power”** to switch-on the unit.
3. Switch-on the programmer, then press button **“3”** to enter to Configuration mode (Figure 14).
4. Input the **“5”** for **Check** mode then press **“Write”** to change the setting (Figure 15).

Note: If display **“Success”**, means the entered mode is confirmed. If display **“Fail”**, means failure to program the mode.

5. Press **“Exit”** key to go back Main Menu. Press **“Power”** to switch off the programmer.

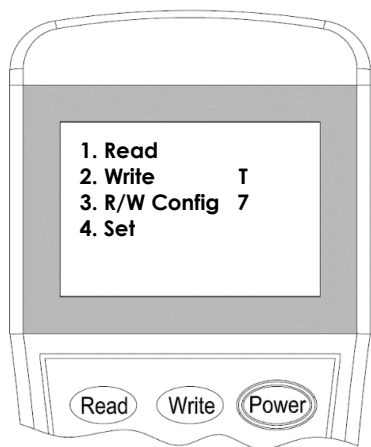

Figure 14

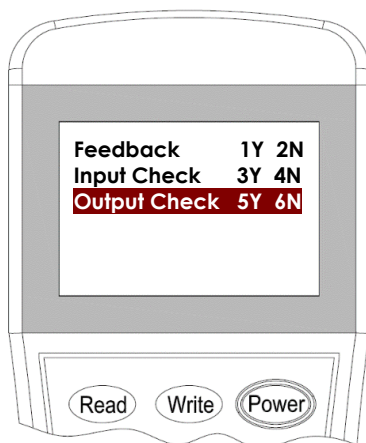

Figure 15

Parameter Description
5Y Enable Output Check Mode
6N Disable Output Check Mode (Default)

3.6 Read Configuration

1. Connect the programming cable to Z1 and Z2 terminals (Figure 6). Press **“Power”** to switch-on the unit.
2. Switch-on the programmer, then press button **“Read”** or **“1”** to enter to Read mode (Figure 16). The programmer will display the configuration after few seconds. (Figure 17).
3. Press **“Exit”** key to go back Main Menu. Press **“Power”** key to switch off the programmer.

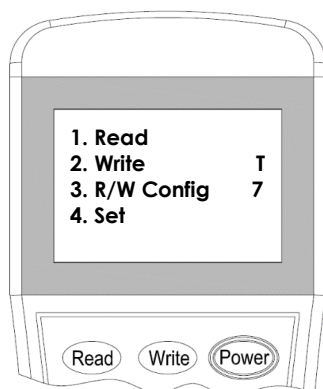

Figure 16

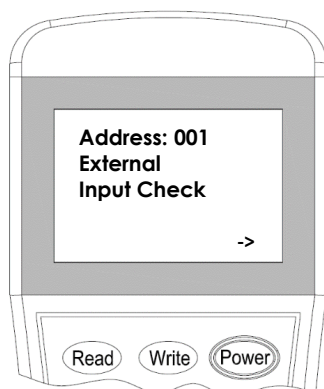

Figure 17



Parameter Description
Address: Unique number assigned
1Y Self-Feedback Mode
2N External-Feedback Mode (Default)
3Y Enable Input Check Mode
4N Disable Input Check Mode (Default)
5Y Enable Output Check Mode
6N Disable Output Check Mode [Default]
ID: Device serial number

4 General Maintenance

1. Inform the suitable personnel before conducting the maintenance.
2. Disable the interface module on the control panel to prevent false alarm.
3. Do not attempt to repair the circuitry of the interface module, it may affect the operation to respond to a fire condition and will void the manufacturer's warranty.
4. Use a damp cloth to clean the surface.
5. Notify again proper personnel after conducting the maintenance and make sure to enable the interface module and confirm if up and running.
6. Perform the maintenance on semi-annually or depending on the site conditions.

5 Troubleshooting Guide

What you notice	What it means	What to do
Address not enrolling	The wiring is loose The address is duplicate	Conduct maintenance Re-Commission the device
Unable to commission	The damage the electronic circuit	Replace the device

Appendix 1

Limitation of Interface Module

The Interface Module cannot last forever. In order to keep the interface module working in good condition, please maintain the equipment continuously according to recommendations from manufacturers and relative nation codes and laws. Take specific maintenance measures on the basis of different environments.

These interface module contains electronic parts. Even though it is made to last for a long period of time, any of these parts could fail at any time. Therefore, test your module at least every half-year according to national codes or laws. Any interface module, fire alarm devices or any other components of the system must be repaired and/or replaced immediately as they fail.