

# TX7100

Intelligent Addressable Optical Smoke Detector  
Installation and Operation Manual



## Product Safety

To prevent severe injury and loss of life or property, read the instruction carefully before installing the detector to ensure proper and safe operation of the system.



### European Union directive

2012/19/EU (WEEE directive): Products marked with this symbol cannot be disposed of as unsorted municipal waste in the European Union. For proper recycling, return this product to your local supplier upon the purchase of equivalent new equipment, or dispose of it at designated collection points.



For more information please visit the website at [www.recyclethis.info](http://www.recyclethis.info)

## Table of Content

1 Introduction.....	4
1.1 Overview .....	4
1.2 Feature and Benefits .....	4
1.3 Technical Specification .....	4
2 Installation .....	5
2.1 Installation Preparation.....	5
2.2 Installation and Wiring .....	5
3 Detector Configuration .....	6
3.1 Preparation .....	6
3.2 Write: Addressing .....	6
3.3 Set: LED On/Off .....	6
3.4 Read Configuration .....	7
4 General Maintenance .....	7
4.1 Cleaning .....	8
5 Troubleshooting Guide .....	8
Appendix 1 .....	9
Limitation of Smoke Detectors.....	9

## 1 Introduction

### 1.1 Overview

The TX7100 Intelligent Addressable Optical Smoke Detector is the ideal device for most applications, due to its spiffing linear response to a wide variety of different types of smoke patterns. The unit manufactured the sensitivity requirement of EN 54 part 7, European Standard. The unit is aesthetically pleasing with unobtrusive design that will complement modern building designs. The unit incorporates an intelligent processor that provides Algorithm map, inbuilt A/D converter, Drift compensation, and Self-Diagnosis and History log.

Secure and speedy communication through the on-board processor enables the detector to make its own decision, resulting in greater automation. In the event of fire, the integral microprocessor analyses the signal according to factors such as signal strength and rate of increase, then confirms these patterns with the pre-programmed fire scenarios and smoke patterns, for a faster and safer response. Once it is confirmed, the LED indicates the sensor status and parallel sending communication signal to the control panel. The TX7100 detector is compatible to the TX7004 Analogue Intelligent Fire Alarm Control Panel, produced by single manufacture T&A, to avoid addressable communication compatibility problem.

### 1.2 Feature and Benefits

- EN54-7 Compliance
- Using microprocessor technology with memory capacity up to 10 events
- Analogue sending and digital addressing
- Provide real time algorithm to the control panel
- Smart linear drift compensation
- Onsite adjustable parameter
- 360 degree visual indicator
- Removable chamber against dust and small insect
- Ancillary remote indicator output
- Aesthetically pleasing design

### 1.3 Technical Specification

- |                               |  |
|-------------------------------|--|
| • Listed                      | LPCB Pending                               |
| • Compliance                  | EN54-7                                     |
| • Input Voltage               | 24VDC [16V to 28V]                         |
| • Current Consumption Standby | 0.6mA, Alarm: 4mA                          |
| • Protocol/Addressing         | T&A, Value range from 1 to 254             |
| • Sensitivity                 | As per stipulated standard                 |
| • Indicator                   | Single LED / 360 degree Visual             |
| • Material / Colour           | ABS / White Glossy finishing               |
| • Dimension / Height          | Diameter 99.7 mm / 57 mm                   |
| • Weight                      | 145g (with Base), 90g (without Base)       |
| • Operating Temperature       | -10°C to +50°C                             |
| • Humidity                    | 0 to 95% Relative Humidity, Non condensing |

## 2 Installation

### 2.1 Installation Preparation

This detector must be installed, commissioned and maintained by a qualified or factory trained service personnel. The installation must be installed in compliance with all local codes having a jurisdiction in the area or BS 5839 Part 1 and EN54.

The TX7100 Optical smoke detectors operate on the principle of infra-red light refracting off smoke particles entering the chambers. This makes detector more sensitive to smouldering fires such as modern fabric or furnishing. Optical detectors are more prone to false alarm from steam or dusty environment. For best sensing ability, avoid installing the smoke detector in these areas.

- In open air applications as the detectors require ceilings to direct the smoke from the plume by convection.
- On side walls, this will severely delay the response time of a detector and where ceiling heights exceed 10.5m.
- In Rooms where cooking will take place such kitchens, or similar areas where steam and condensation are present.
- Where exhaust fumes are present like car parks.
- Where smoke particles will not be produced by fire.
- Plant Rooms (unless full discussions regarding the room contents and status subject to a fire have been made between Client and Manufacturer), Boiler and Generator Rooms.

### 2.2 Installation and Wiring

1. Mount the T&A standard base on standard one [1] gang electrical back box. Do not over-tighten the screws otherwise the base will twist. Use M4 standard screws.
2. Connect the wire in terminal as shown in Figure two [2]. Verify the device number or other device parameters if desired using handheld programmer then stick on the label before attaching detector. The sticker labels are available on the control panel.
3. Attach the detector to the base, point the detector in the base by the mark-line and secure the detector in that position by rotating it clockwise, until it reaches the next mark line.
4. Do not remove the red plastic dust cover until the final handover is done.

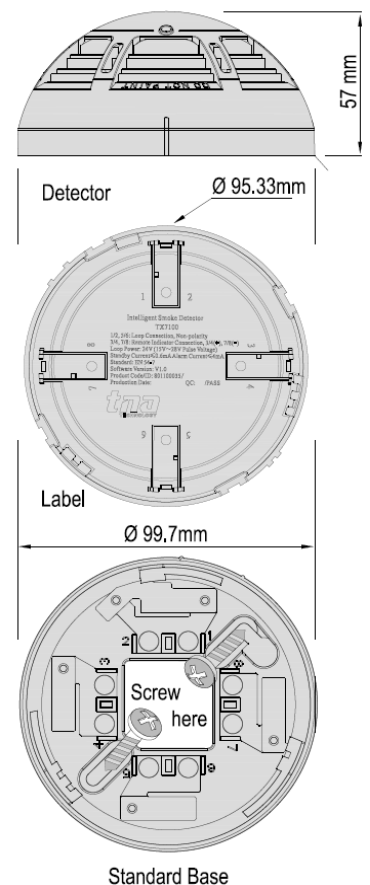

Figure 1

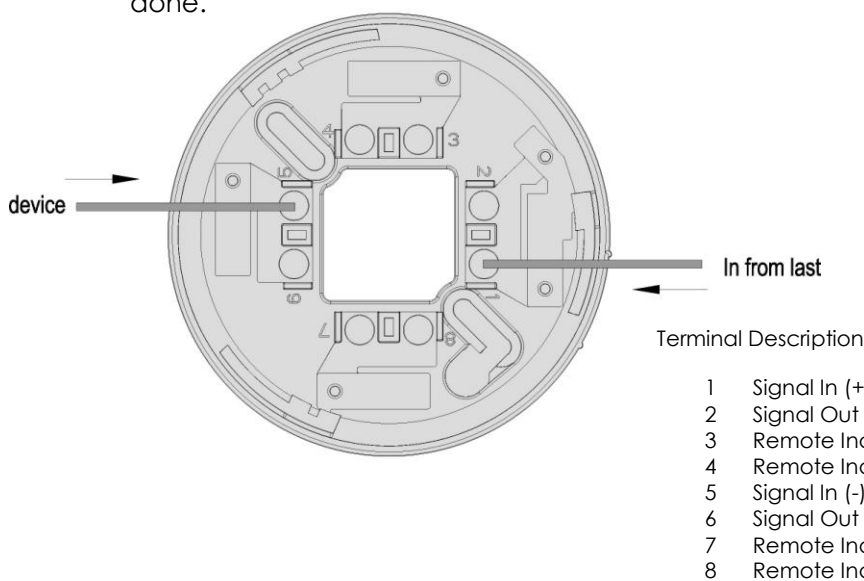

Figure 2

### 3 Detector Configuration

#### 3.1 Preparation

The TX7930 handheld programmer is used to configure smoke detectors soft address and parameter. This tool is not included, must be purchased separately. The programmer is packed with twin 1.5V AA battery and cable, ready for usage once received.

It is mandatory for the commissioning personnel to have programmer tool in order to adjust the detector conferring to the site situation and environmental requirements.

Program a unique address number for each device according to the project layout before placing from the Terminal Base.

**Warning:** Disconnect the loop connection whilst connecting to the handheld programmer.

#### 3.2 Write: Addressing

1. Connect the programming cable to 1 and 6 terminals (Figure 3). Press **"Power"** to switch on the unit.
2. Switch-on the programmer, then press button **"Write"** or number **"2"** to enter Write Address mode (Figure 4).
3. Input the desired device address value from 1 to 254, and then press **"Write"** to save the new address (Figure 5).

**Note:** If display **"Success"**, means the entered address is confirmed. If display **"Fail"**, means failure to program the address (Figure 6).

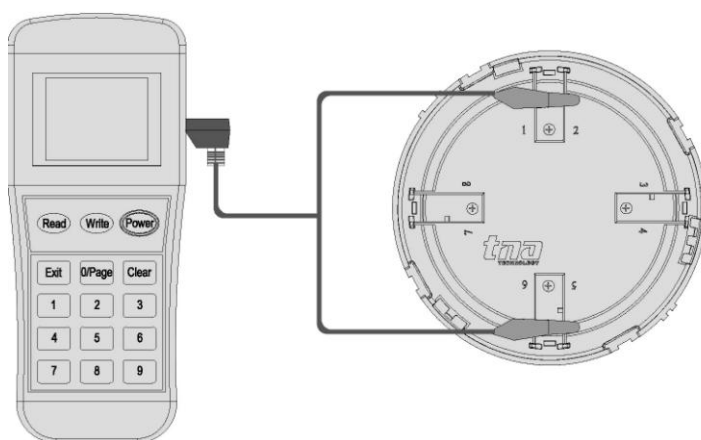

Figure 3

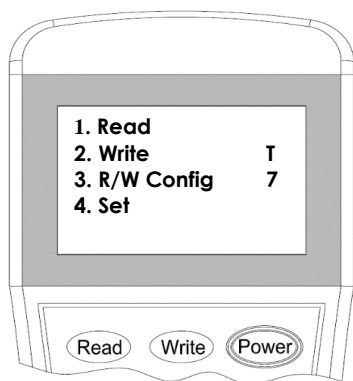

Figure 4



Figure 5



Figure 6

4. Press **"Exit"** key to go back Main Menu. Press **"Power"** key to switch-off the programmer.

#### 3.3 Set: LED On/Off

1. The LED indicator can be turned off if desired, the sensing ability of the detector will not be disrupted even if the LED is off.
2. Attach the programming cable to 1 and 6 terminals of the detector. Press **"Power"** to switch on the unit.
3. Switch on the programmer, then press button **"4"** to enter the setting mode (Figure 7).
4. Input the **"1"** then press **"Write"** to change the setting (Figure 8) and the LED will turn off. To resume the default setting, press **"Clear"** and then press **"Write"**.

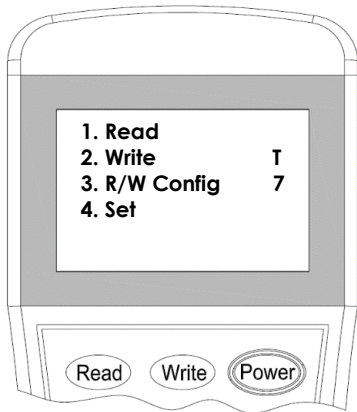

Figure 7

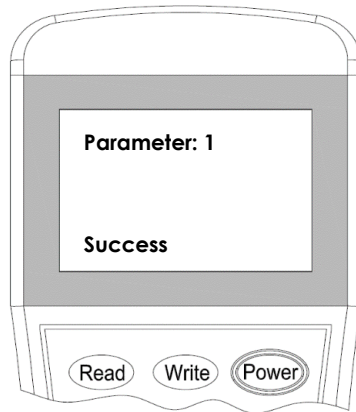

Figure 8

Parameter Description	
0-	LED On (Default)
1-	LED Off

5. Press “**Exit**” key to go back Main Menu. Press “**Power**” to switch off the programmer.

### 3.4 Read Configuration

1. Attach the programming cable to 1 and 6 terminals of detector. Press “**Power**” to switch on the unit.
2. Switch-on the programmer, then press button “**Read**” or “**1**” to enter to Read mode (Figure 9). The programmer will display the configuration after few seconds. (Figure 10).

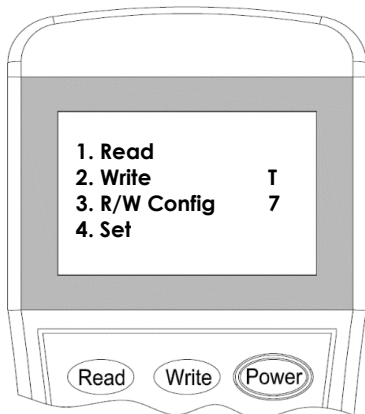

Figure 9

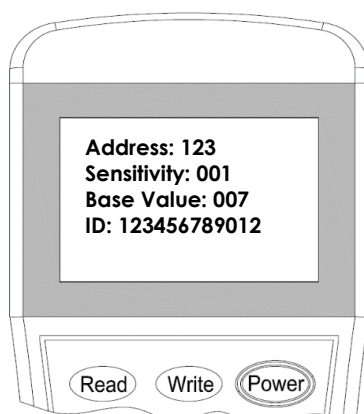

Figure 10

Read Description	
<b>Address:</b>	Unique number assigned
<b>Sensitivity:</b>	For future use
<b>Base Value:</b>	Detector status value
<b>ID:</b>	Detector serial number

3. Press “**Exit**” key to go back Main Menu. Press “**Power**” to switch off the programmer.

### 4 General Maintenance

1. Inform the suitable personnel before conducting the maintenance.
2. Disable the detector on the control panel to prevent false alarm.
3. Do not attempt to adjust or modify the detector, it may affect the ability of the detector to respond to a fire condition and will void the manufacturer’s warranty.
4. Use a damp cloth to clean the detector. Do not use cleaning chemicals that may leave residue on the electronic parts and smoke chamber.
5. Notify again proper personnel after conducting the maintenance and make sure to enable the detector and confirm if up and running.
6. Perform the maintenance on semi-annually or quarterly depending on the site conditions.

#### 4.1 Cleaning

1. Remove the detector cover by snipping away the four sides tabs using a flat screw driver and then pulling the cover from the base. (Figure 11).
2. Remove the protective screen by pulling it straight out. (Figure 12).
3. Carefully vacuum the chamber and screen. If there is stain, wash with running water and ensure it is completely dry.
4. Position the chamber and screen by aligning three tiny holes over the sensing component. (Figure 12).
5. Align the LED tube and tabs and gently pushing the cover until it locks into place. (Figure 12).
6. Re-install and test the detector.

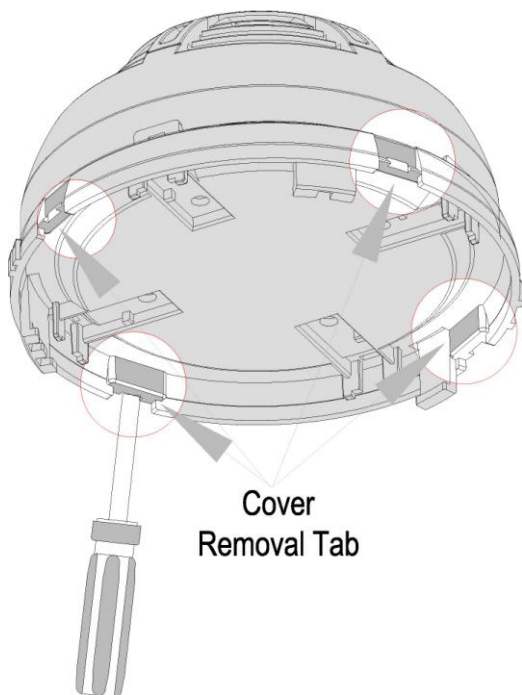

Figure 11

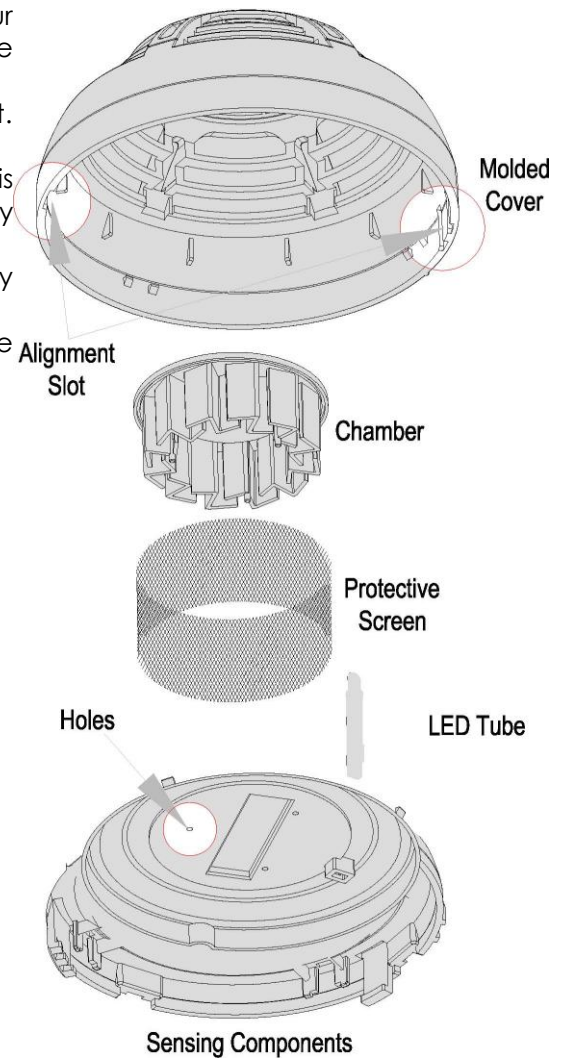

Figure 12: Exploded View

#### 5 Troubleshooting Guide

What you notice	What it means	What to do
Address not enrolling	The wiring is lose The address is duplicate	Conduct maintenance Re-Commission the detector
Unable to commission	The damage the electronic circuit	Replace the detector
Keep Indicating Fire signal	The detector chamber is dirty	Clean the detector



## Appendix 1

### Limitation of Smoke Detectors

The smoke detector is designed for triggering and initiating emergency fire equipment, however it only functions when matching with other equipment's. Installation of this smoke detector must conform to electrical codes and country standards.

All kinds of smoke detector have restrictions, since fire develops in various ways and are often unpredictable in their progression, it is unforeseeable which type of detector will provide the earliest warning. No types of smoke detector can sense every form of fire all the time. Generally speaking, detectors may not warn you about fire caused by insufficient safety measures, violent explosions, leaking gas, improper storage of flammable materials like diluents and other safety hazards, arson or children playing with fire. The alarm of a smoke detector used in high velocity environment will be delayed due to dilution of smoke by frequent and fast airflow. What's more, the smoke detector has to be frequently maintained for it is exposed to more dust contamination.

The smoke detector cannot last forever. In order to keep the detector working in good condition, please maintain the equipment continuously according to recommendations from manufacturers and relative nation codes and laws. Take specific maintenance measures on the basis of different environments.

The smoke detector contains electronic parts. Even though it is made to last for a long period of time, any of these parts could fail at any time. Therefore, test your smoke detector at least every half-year according to national codes or laws. Any smoke detectors, fire alarm devices or any other components of the system must be repaired and/or replaced immediately as they fail.